

mini FLOWATCH® 2 COMFORT

SICCOM

The best-selling mini pump in a quieter and easy-to-install version, for the condensate removal of air conditioners up to 10kW / 36000BTU.

Ref: DE05LCD750



PREMIUM

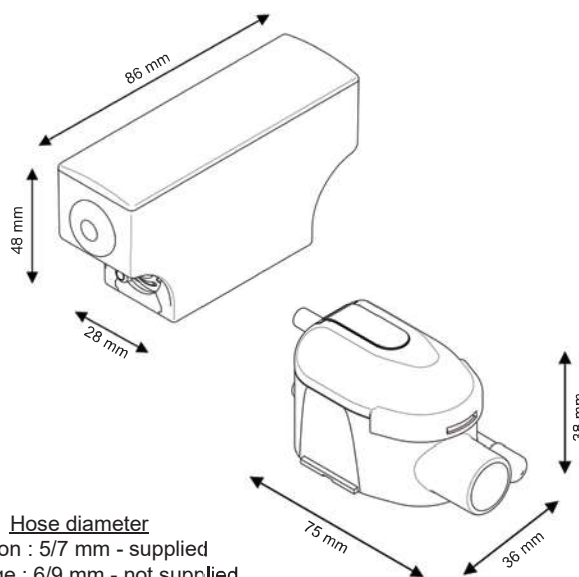

Hose diameter
Suction : 5/7 mm - supplied
Discharge : 6/9 mm - not supplied

SPECIFICATIONS

Flowrate max	15 l/h
Suction head max	2 m
Discharge head max	10 m
Electrical power	19W
Voltage	220-240V 50/60Hz
Alarm	NO-NC
Noise level	
Protection rating	IP64
Thermal protection	Yes
Operating cycle*	100%
Power / alarm cable	1.6 m
Dimensions	86 x 28 x 48 mm / 75 x 38 x 36 mm
Certifications	CE, UKCA, EAC, CMIM

* The pump is able to run 100% of the time if necessary.

BENEFITS



New casing Comfort

The new Comfort casing is composed of a custom-made patented foam.

It dampens pump vibrations and reduces the perceived noise level.



Reliability proven

The mini FLOWATCH® 2, included, is a reliable and durable pump sold in more than 45 countries.



Very silent

Thanks to its casing, the pump is very quiet and suitable for installation in any room.



Stop Vibrations premounted

Eliminates vibrations transmitted to the discharge pipe, thus reducing the noise level of the system!



Pump stand included

Make pump installation and maintenance easier.



Stop siphoning included

Allows to avoid all risk of negative discharge and to secure the pump functioning over time.



Plug & Play connectors

Make installation and maintenance easier.

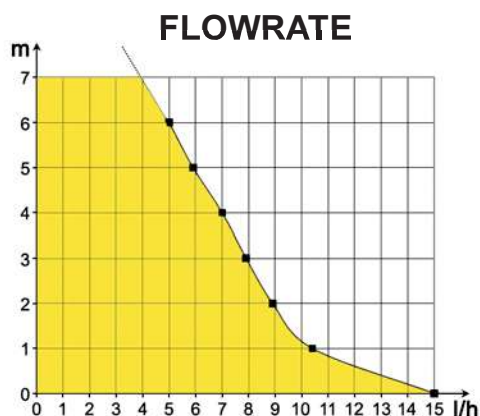

CONTENTS

Pump - Reservoir with air-vent tube - Power / alarm cable - Comfort casing - Pump stand - Reservoir stand - Stop Vibrations - Stop Siphoning - Double-sided adhesive - Inlet tube - Suction tube 1.8m - 4 clamps