

mini FLOWATCH® 0

SICCOM

Mini solenoid pump simple and economic for the condensate removal of air conditioners **up to 8kW / 27000BTU**.

Ref: DE05LCB980

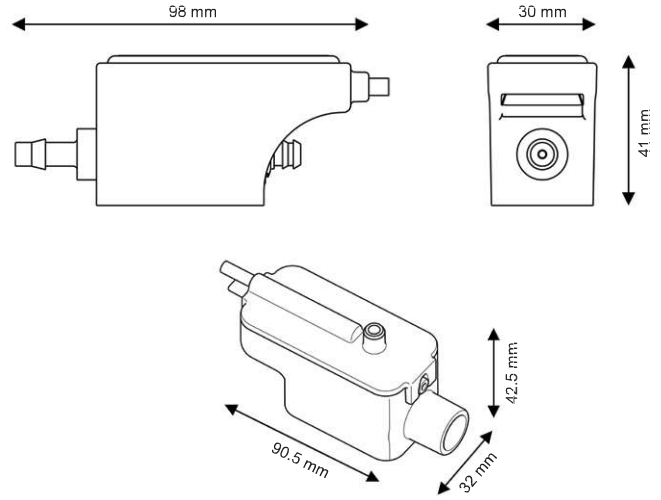

Hose diameter
Suction : 6/9 mm - not supplied
Discharge : 6/9 mm - not supplied

SPECIFICATIONS

| | |
|--------------------|-----------------------------------|
| Flowrate max | 10 l/h |
| Suction head max | 1.5 m |
| Discharge head | 10 m |
| Electrical power | 11W |
| Voltage | 220-240V 50Hz only |
| Alarm* | No alarm |
| Noise level** | |
| Protection rating | IP20 |
| Thermal protection | Yes |
| Operating cycle*** | 100% |
| Power cable | 1.5 m |
| Dimensions | 98 x 30 x 41 mm / 90 x 32 x 42 mm |

* Alarm option available on request.

** Notation from 1 wave (≤ 20 dBA) to 6 waves (> 45 dBA)

*** The pump is able to run 100% of the time if necessary.

BENEFITS



WATERPROOF removable reservoir
The reservoir, which can be removed for easy maintenance, now has a waterproof seal!



Integrated filter
Plastic filter integrated to the reservoir. It prevents big impurities to damage the pump.



Accessories included
All necessary accessories are included in the box.



Compact pump
Very small, pump and reservoir are easy to install.

FLOWRATE

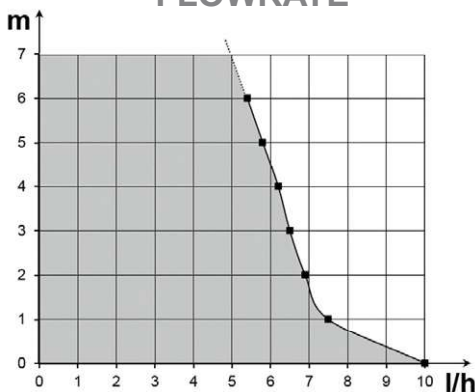

CONTENTS

Pump - Reservoir - Double-side adhesive for reservoir fixing - Inlet tube - 3 clamps

