

# MAXI ECO FLOWATCH®

**SICCOM**

Maxi solenoid pump, compact and powerful, for the condensate removal of air conditioners up to 30kW / 100 000BTU.

Ref: DE40LCC300



ECO

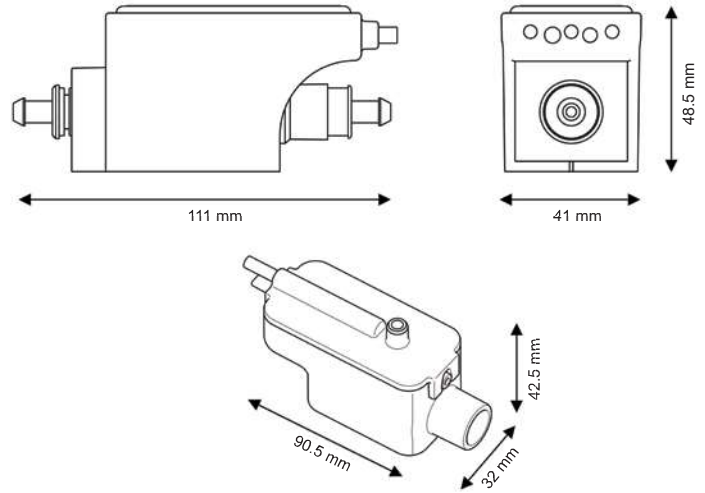
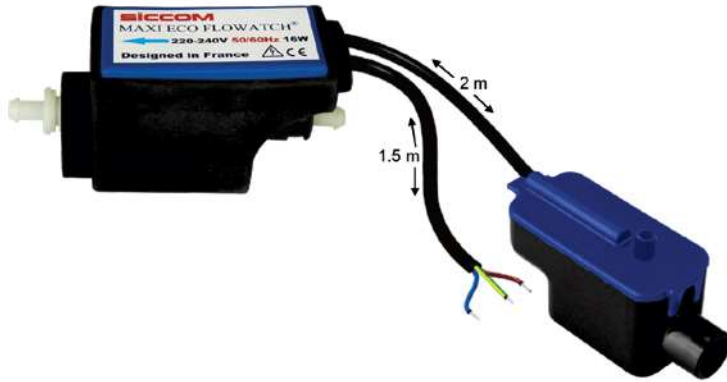

Hose diameter

Suction : 6/9 mm - not supplied  
Discharge : 6/9 mm - not supplied

## SPECIFICATIONS

Flowrate max	40 l/h
Suction head max	2 m
Discharge head max	10 m
Electrical power	16W
Voltage	220-240V 50/60Hz
Alarm*	No alarm
Noise level	
Protection rating	IP20
Thermal protection	Yes
Operating cycle**	100%
Power cable	1.5 m
Dimensions	111 x 41 x 48 mm / 90 x 32 x 42 mm
Certifications	CE, EAC

\* Alarm option available on request.

\*\* The pump is able to run 100% of the time if necessary.

## FLOWRATE

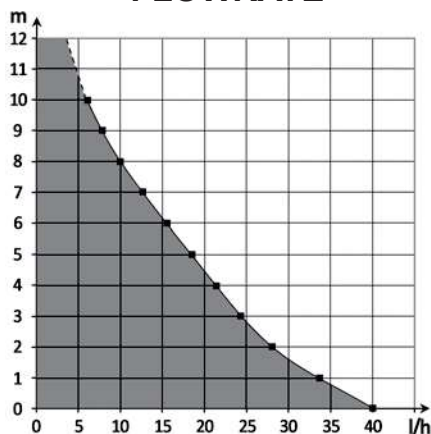

## BENEFITS



### High efficiency

Flowrate 40 l/h  
Discharge head 10 m



### Silent

The only pump of the world to offer such a flowrate with such a low noise.



### WATERPROOF removable reservoir

The reservoir, which can be removed for easy maintenance, now has a waterproof seal!



### Integrated filter

Plastic filter integrated to the reservoir. It prevents big impurities to damage the pump.



### Accessories included

All necessary accessories are included in the box.



### Compact pump

Very small, pump and reservoir are easy to install.



## CONTENTS

Pump - Reservoir - Double-side adhesive for reservoir fixing - Inlet tube - 3 clamps